

Aufbauanleitung / assembly instructions mod. 5612 - 5614 & 5616 - 5618 fest

Bitte diese Aufbauanleitung sorgfältig aufbewahren!

Please keep this assembly instructions carefully!

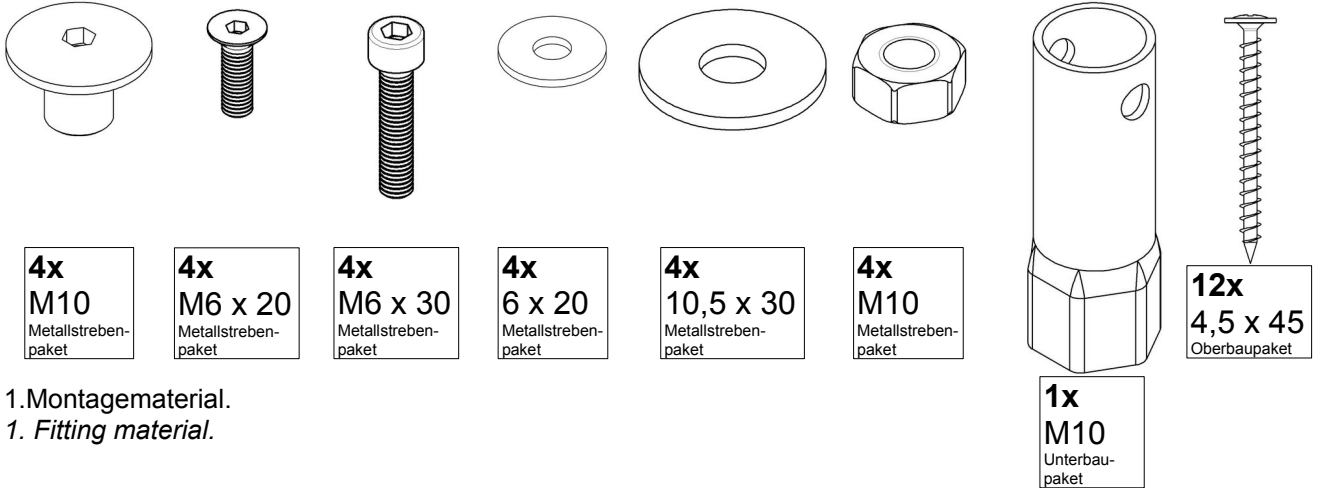

1. Montagematerial.
1. Fitting material.

Achtung, auf die **Ausrichtung** von Säule und Bohrungen achten!
*Pay attention to the **alignment** of the column and the holes!*

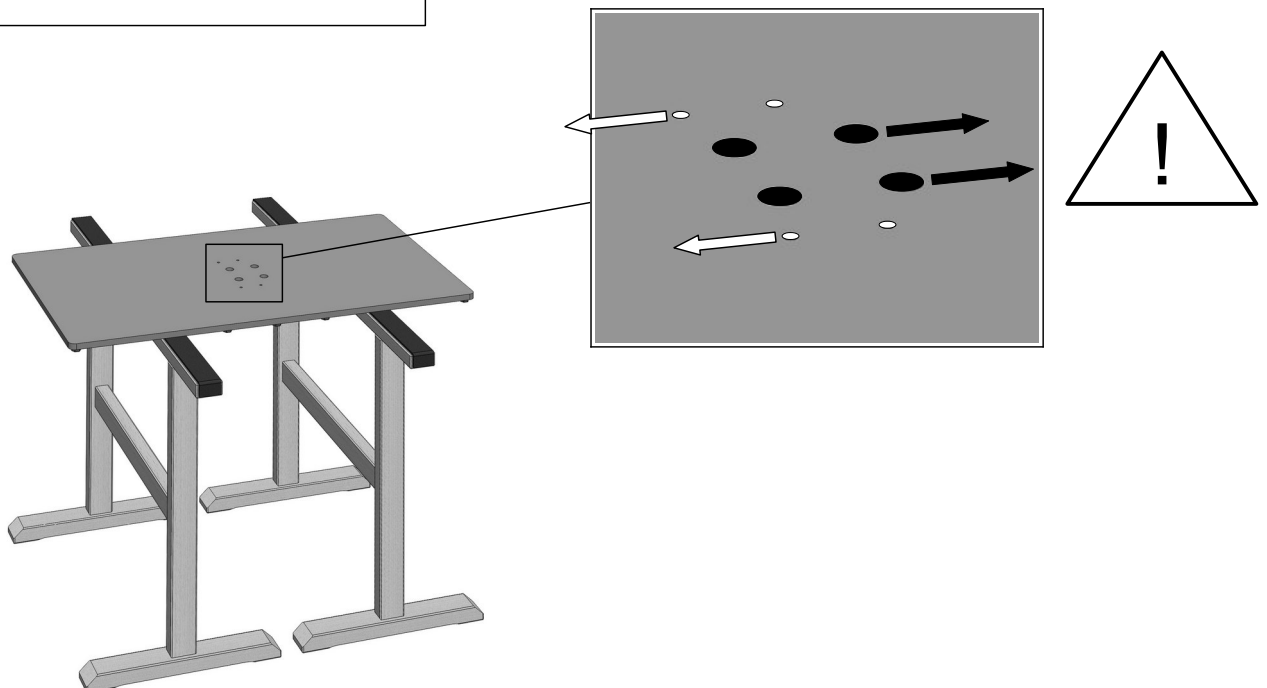

2. Die Stahl Bodenplatte auf gepolsterte Montageböcke legen.
2. Put the steel base plate onto padded assembling trestles.

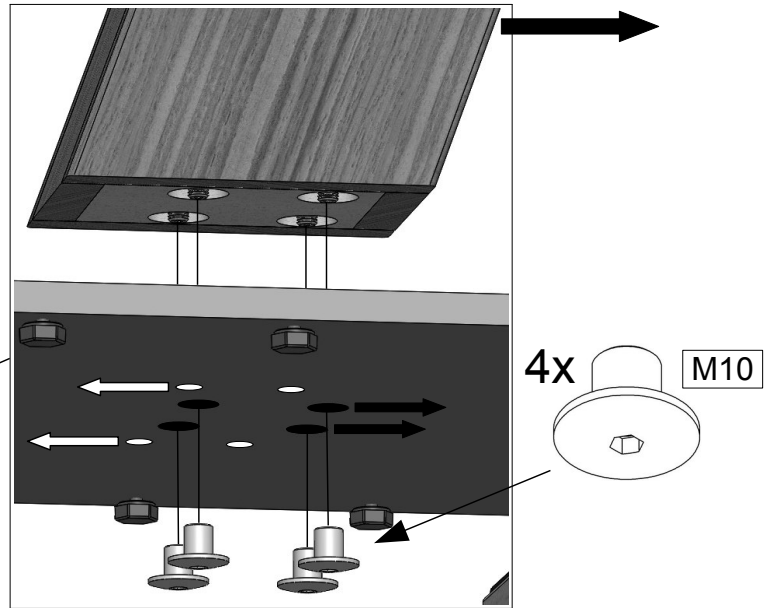
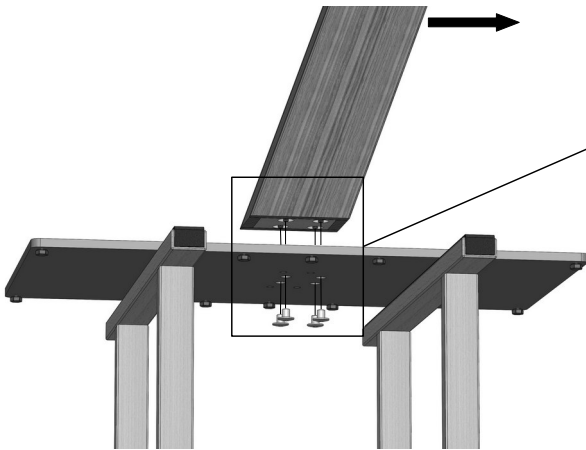
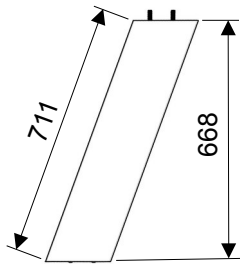

3. Die Holzsäule mit 4 Rundmuttern zunächst **loose** fixieren.
3. First **loosely** fix the wooden table column with 4 round nuts.

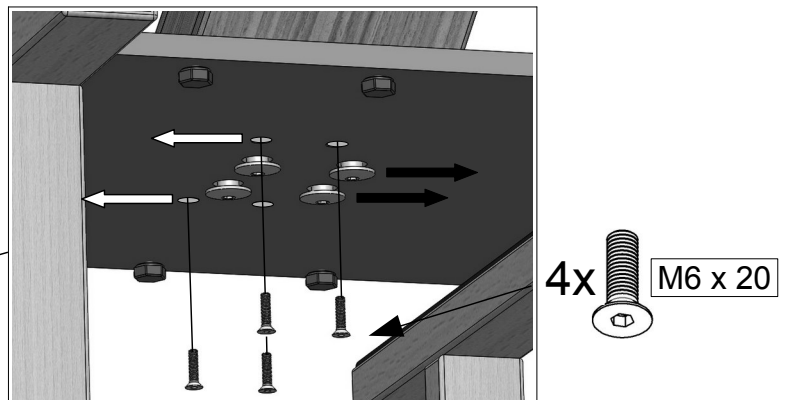
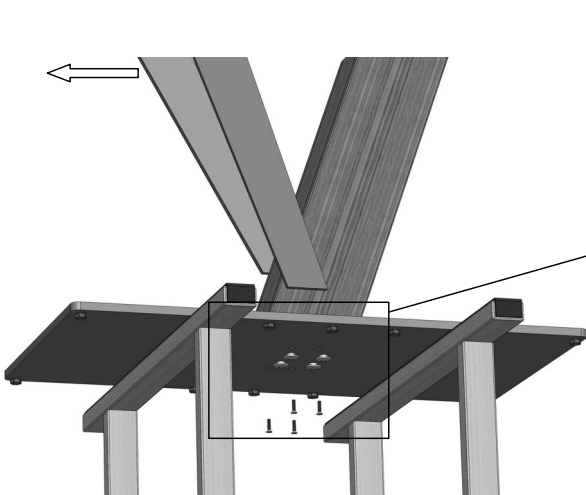

4. Die beiden Metallstreben mit je zwei Senkkopfschrauben fixieren.
4. Fix the two metal bars with each two countersunk screws.

Zur Überprüfung / for verification:

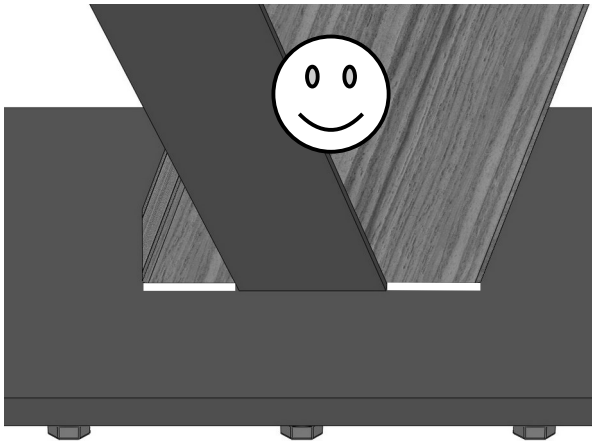

Richtig montiert / Properly mounted.

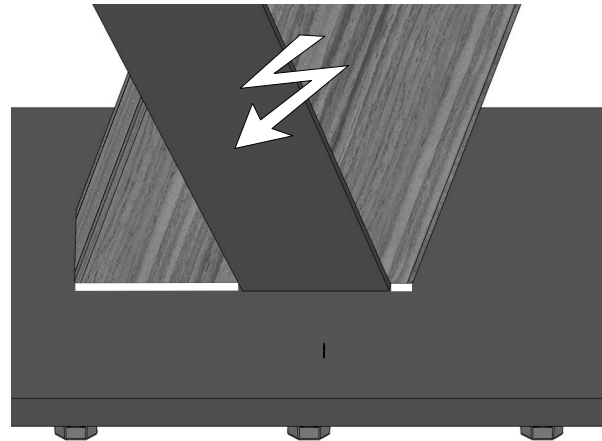

Falsch montiert / Incorrectly mounted.

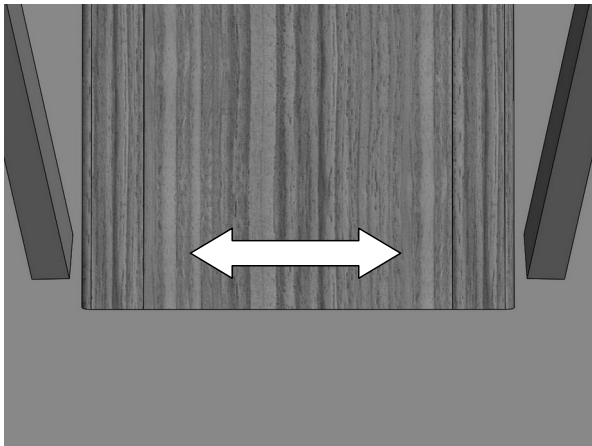

5a. Die Holzsäule mittig zwischen den Metallstreben ausrichten.
5a. Align the wooden column in the middle between the metal struts.

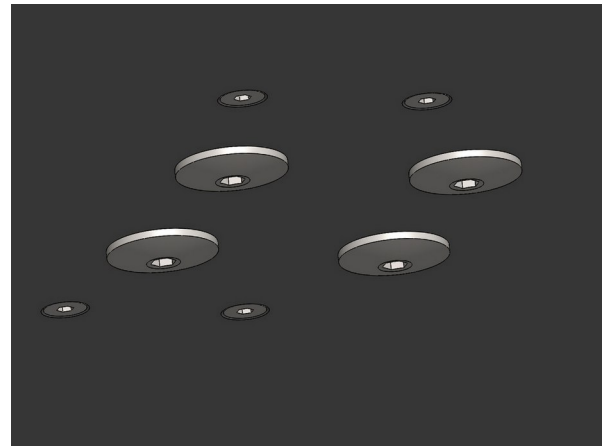

5b. Die vier Rundmutter nun fest anziehen.
5b. Now tighten the four round nuts firmly.

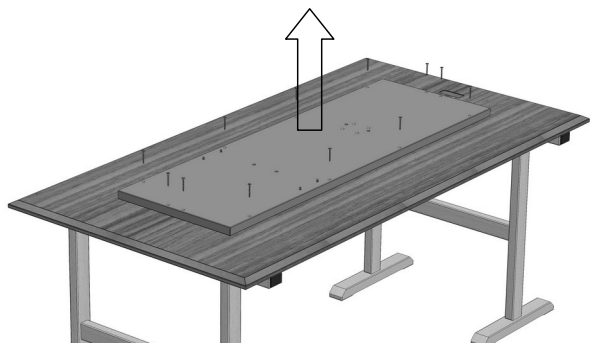

6. Die Halteplatte abschrauben.
6. Unscrew the holding plate.

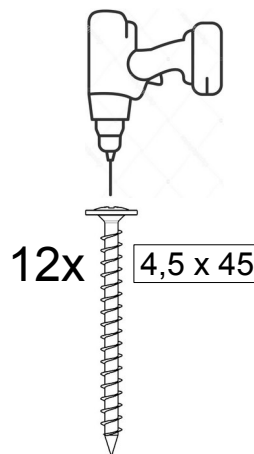

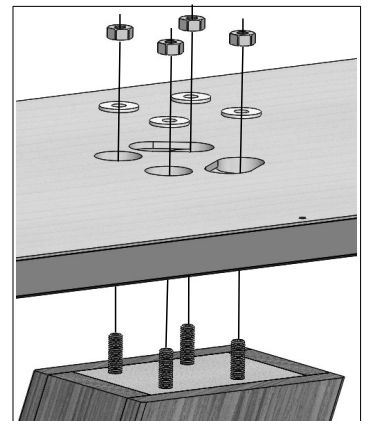
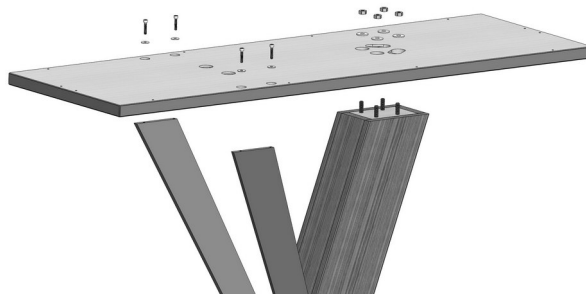
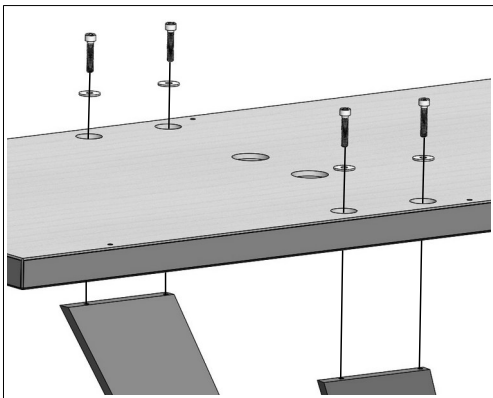
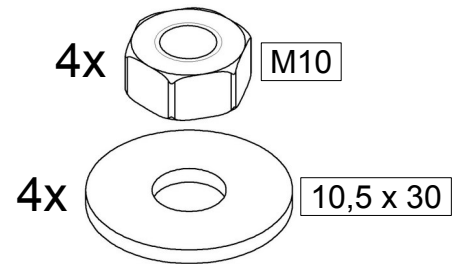
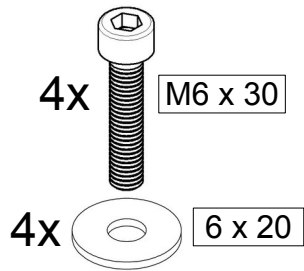

7. Die Halteplatte an den Unterbau montieren.
7. Mount the holding plate to the base.

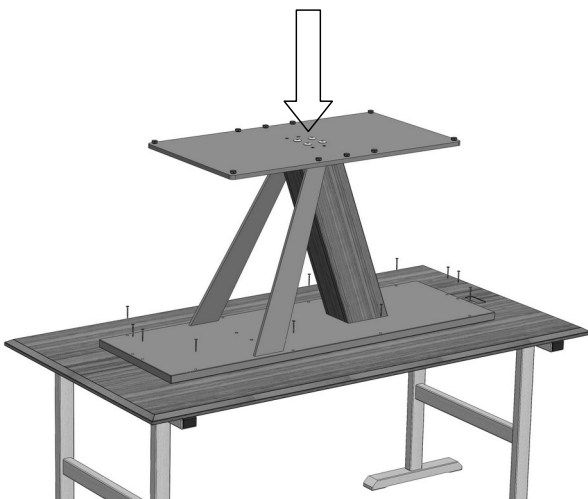

8. Den Unterbau mit dem Oberbau verbinden.
8. *Mount the table base to the table top.*

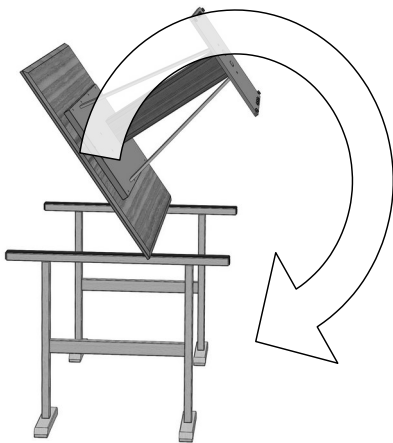
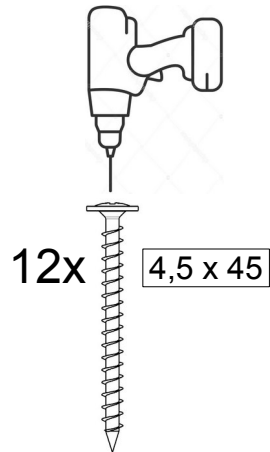

9. Turn the table.
9. *Ready.*



10. Fertig.
10. *Ready.*